

SENERGY Motor Roller (DC-24V) Installation Manual

NOTE: Control card is not contained. Please purchase it separately.

Thank you for purchasing **SENERGY** Motor Roller. These instructions contain important information to enable you to use the products safely and to prevent any harm or damage to you and others. Familiarize yourself with the content before using the products. After reading this manual, be sure to keep in the assigned place.

- Warning:** indicates a potentially hazardous situation, which may result in death or serious injury if improperly handled/used.
- Caution:** indicates a potentially hazardous situation, which may result in injury or property damage if improperly handled/used.

General

- Do not use this product in an explosive atmosphere, flammable gas atmosphere, corrosive atmosphere, a place exposed to water splashes, or a place close to combustibles. It may cause an explosion, injury, or fire. (Use the waterproof type when the product is exposed to water splash environment.)
- After confirming the DC power supply, supported voltages and specifications of the Motor Roller, connect them carefully not to make a mistake.
- Do not conduct such operations as move, installation, connection, and inspection while the power is on. Be sure to conduct such operations after turning off the power in order to be safe from electric shock.
- Do not use Motor Roller in any way beyond its specifications. It may cause an injury or fire.
- Be sure to ground the frame of the conveyor / equipment.

Caution

- Determine the number of Motor Rollers in consideration of the performance/characteristics. (The motor will generate heat when used in an overload condition, resulting in a shorter product life-cycle.)
- Handle the Motor Rollers with care because the surface temperature of the tube can be high depending on the conditions of use.
- Do not repair, alter, or disassemble Motor Rollers. It may cause an electric shock, injury, or failure.

Precautions for use

- Use the Motor Roller in the usage environment of ambient temperatures ranging from -10 to +40°C and relative humidity ranging from 10 to 90% (non condensing).
- Do not apply strong impact, such as dropping or striking the Motor Roller.
- Do not carry the Motor Roller by holding the cable, and do not pull or replace the connector. Be careful not to damage the wire-coating while drawing the cable through fixing parts and frame.
- Mount the Motor Roller and idler rollers in the same level so that they are evenly loaded.

Storage method

- Never store or leave the Motor Roller outdoors. (It may cause a short circuit or rust.)
- Store the Motor Roller in the environment of ambient temperatures ranging from -30 to +40°C and relative humidity ranging from 10 to 90% (non condensing).
- Store the Motor Roller horizontally because grease is enclosed inside.

Checks after unpacking the carton

- Check the product label on End-plate at the cable side of the Motor Roller to confirm that Part number matches to your order.
- Check that 1 Fixing parts set is included per Motor Roller. (In case of threaded shaft spec, Nut and Washer are included.)
- Check the type and Part number of Fixing parts.

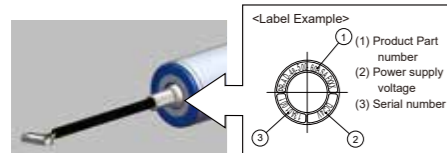

<Label Example>
 (1) Product Part number
 (2) Power supply voltage
 (3) Serial number

<Example of Part Number>
 PR-A-D-50-500-60-ZSAC
 *Various specifications
 *Speed code
 *Roller length
 *Diameter
 *DC24V
 *Specification
 Abbr. of PULSE ROLLER
 For the details of the fields marked with "", refer to the catalog.

Dimensional drawing

D: Roller diameter (φ48.6/φ50/φ57/φ60.5)

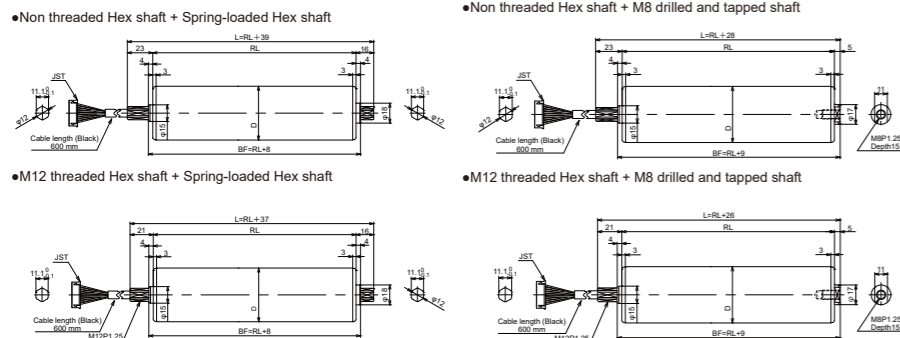

Fixing parts for Non threaded Hex shaft [cable side]

[Point-up brackets:○]
 PR-D-30H-PU-N
 PR-D-30H-PU-N-ST (Short footprint)

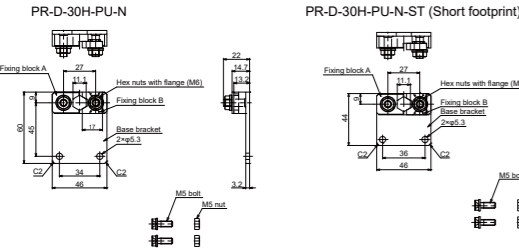

[Flat-up brackets:○]
 PR-D-30H-FU-N
 PR-D-30H-FU-N-ST (Short footprint)

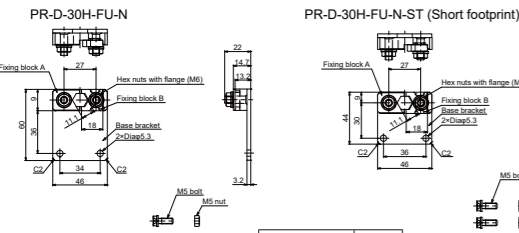

Items	Quantity
Base bracket	1 piece
Fixing block A	1 piece
Fixing block B	1 piece
M5 bolt and nut	2 sets
M6 flange nut	2 pieces

Item	Quantity
M12 nut with outward washer	1 piece

Fixing accessory for M8 drilled and tapped shaft [non-cable side]

Item	Quantity
M8 Hex bolt with captive washer	1 piece

Recommended frame hole dimensions

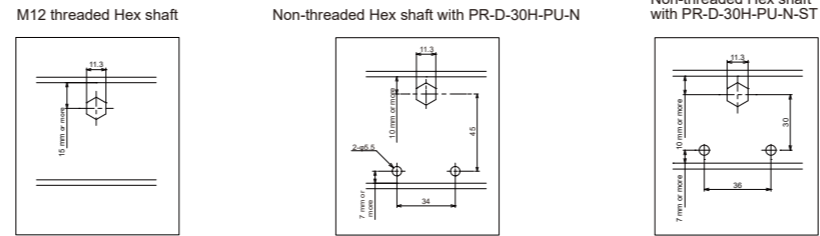

Caution

- For Tapered Motor Roller or Skewed roller installation exceeding 1mm miss-alignment of axle holes, please do NOT use our standard fixing bracket in order to avoid internal mechanical stress which results in product failure.
- For 1.8 degree Tapered roller mounting, please use such designated bracket or in case of flange nut fixing, apply "angle compensation" with the mounting frame so that cable end shaft certainly sits at 90 degrees against the frame in order to avoid internal mechanical stress which results in product failure.

<Frame top view>

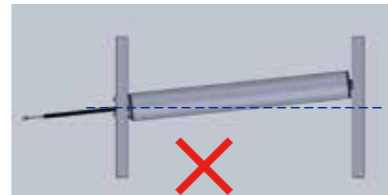

<Frame side view>

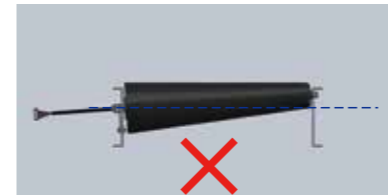

Before installing

Caution

- Be careful not to damage the cable while drawing it through the conveyor frame or fixing parts.
- Securely install Motor Roller with the fixing parts (Motor Roller will rattle in the frame or run idle if the shaft is not secured, which will be resulted in failure.)

STEPS

Mount Motor Roller in accordance with "Reference No." in the following correspondence table.

	Cable side	Non-cable side	Fixing parts	Reference No.
①	M12 threaded Hex shaft + M8 drilled and tapped shaft		M12 nut with outward washer	1→2A→3A→4
②	M12 threaded Hex shaft + Spring-loaded Hex shaft		M12 nut with outward washer	1→2B→3A
③	Non-threaded Hex shaft + M8 drilled and tapped shaft		PR-D-30H-□ U-N(-ST)	1→2A→3B→4
④	Non-threaded Hex shaft + Spring-loaded Hex shaft		PR-D-30H-□ U-N(-ST)	1→2B→3B

Installation

1 -Cable side-

Put the connector and cable through mounting hole of the frame, and insert the shaft to the frame.

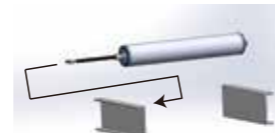

Caution

- Be careful not to damage the cable.

2A -Non cable side- <M8 drilled and tapped shaft>

Push the NON cable side shaft and position it to the mounting hole, then insert M8 Hex bolt with captive washer into the tapped hole on the shaft and fix the shaft temporary.

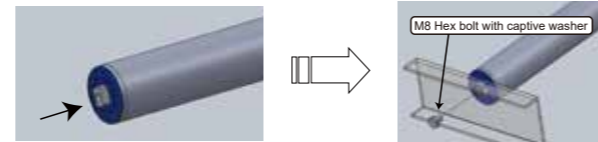

2B -Non cable side- <Spring-loaded Hex shaft>

Push the NON cable side shaft and insert it to opposite side of the conveyor frame. Since the shaft will come out by spring force, the conveyor frames are not required to disassemble for attachment / detachment of the Motor Roller. Shorter length Motor Roller may not have spring-loaded shaft option, so please confirm the specification prior to installation.

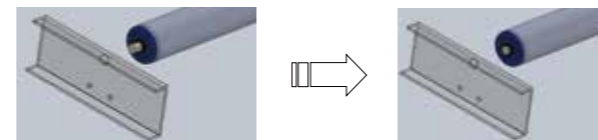

NOTE: Collar part is 4 mm out for φ48 and φ50 Motor Roller.

3A -Cable side- <M12 threaded Hex shaft>

1. Put an outward washer and M12 nut on to the cable side shaft from outside of the frame, then tighten the nut with 32 - 36 Nm.

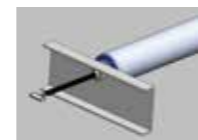

Caution

- Be careful not to damage the cable.
- The shaft will run idle if the tightening is not proper, which may cause a break of the cable or other failures.

3B -Cable side- <Non-threaded Hex shaft>

- Mount Base bracket onto the frame and use a torque wrench to tighten M5 Bolt and Nut with 2.3 - 3.5 Nm.
- Put Fixing block A through the shaft and use a torque wrench to tighten M6 Flange nut with 8 - 10 Nm.

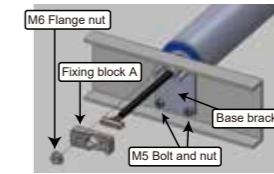

Caution

- Be careful not to damage the cable.
- Tighten the nut slowly with specified torque manually.

- While cable side shaft is being contacted to the frame, put Fixing block B along the shaft and attach it in parallel to the frame.
- Use a torque wrench to tighten M6 Flange nut with 8 - 10 Nm to fix Fixing block B.

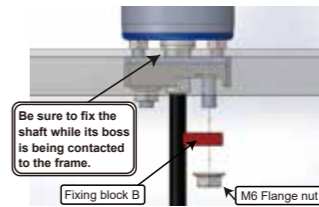

Caution

- Do not use tools which can apply strong impact (e.g., impact wrench). It may cause damage of Fixing block A. Tighten the nut slowly to specified torque manually.
- Be sure to attach Fixing block B in parallel with frame. Failure to do so may cause damage of Fixing block A.
- The shaft will run idle if the tightening is not proper, which may cause a break of the cable or other failures.



4 -Non cable side- <M8 drilled and tapped shaft>

Hold the shaft with a wrench to prevent the shaft from turning and use a torque wrench to tighten the bolt with 10 - 14 Nm.

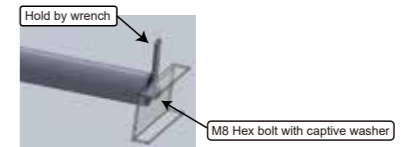

Notice before system operation

- Make sure that there is no contact between Motor Roller and other moving parts.
- Make sure that all screws have been tightened with the specified tightening torque.
- Check that there is no interference with conveyor frame or other equipment.
- Make sure that the wiring procedures have been properly conducted.

Maintenance and measures against failures

Warning

- In the event of anomaly, stop the operation immediately and turn off the power to avoid potential fire, injury, or electric shock.
- Before starting maintenance, ensure that the power supply has been turned off.
- Do not touch Motor Roller with your hand or body during operation and immediately after stopping of operation. It may cause injury due to the heat from the product. Roller surface temperature can be high depending on the conditions of use.

Disposal

- Motor Roller should be wasted as an industry waste in accordance with the regulations of the local municipality.

Warranty

- The warranty period is 1(one) year from delivery of the product under proper installation and handling. The warranty covers only the repair of the main body of the delivered product.

Contact information for Technical support



PULSE ROLLER
 www.pulseroller.com
 sales@pulseroller.com
 support@pulseroller.com
 www.pulseroller.com/contact

USA	Asia	Europe
Insight Automation, Inc. 2748 Circleport Dr. Erlanger, KY 41018, USA Phone : +1 (859)-647-8943	Kyowa Manufacturing Co., Ltd. 570-10, Kubota-cho, Kasai-city, Hyogo prefecture, 675-2364, Japan Phone : +81-790-42-0601	Kyowa Europe GmbH Opladener strasse 2, Halle 7, 42799, Leichlingen Germany Phone : +49 2175 8957160